

# ZIPPER

## an 8-Ft. Catamaran Ski-Boat

This 15-hour do-it-yourself boat project fills enthusiast's bill as planing sports boat, water skier, racer, ski-tow boat, surfboard, fishing raft, or diving platform

By **WILLIAM D. JACKSON**  
Naval Architect

Craft Print Project No. 333

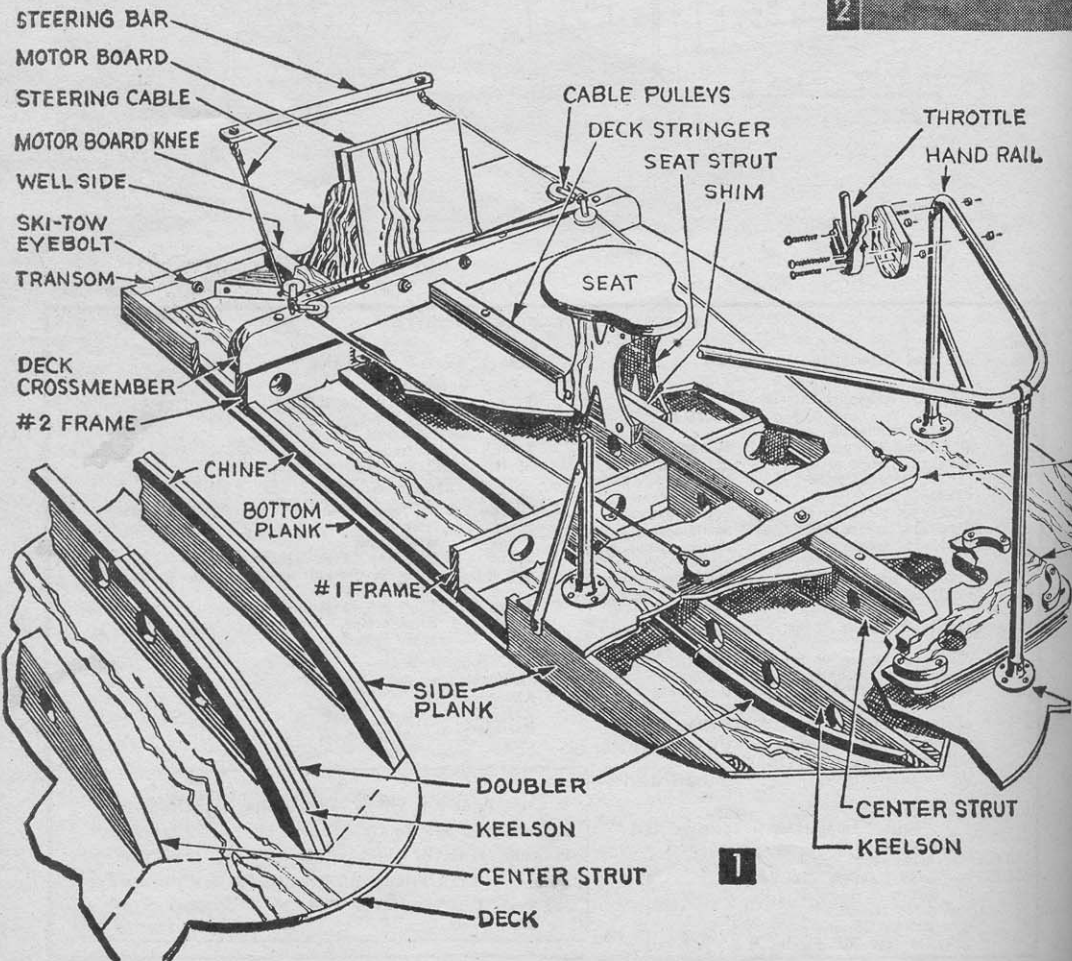
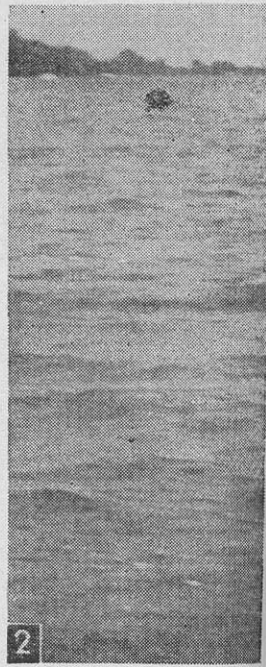

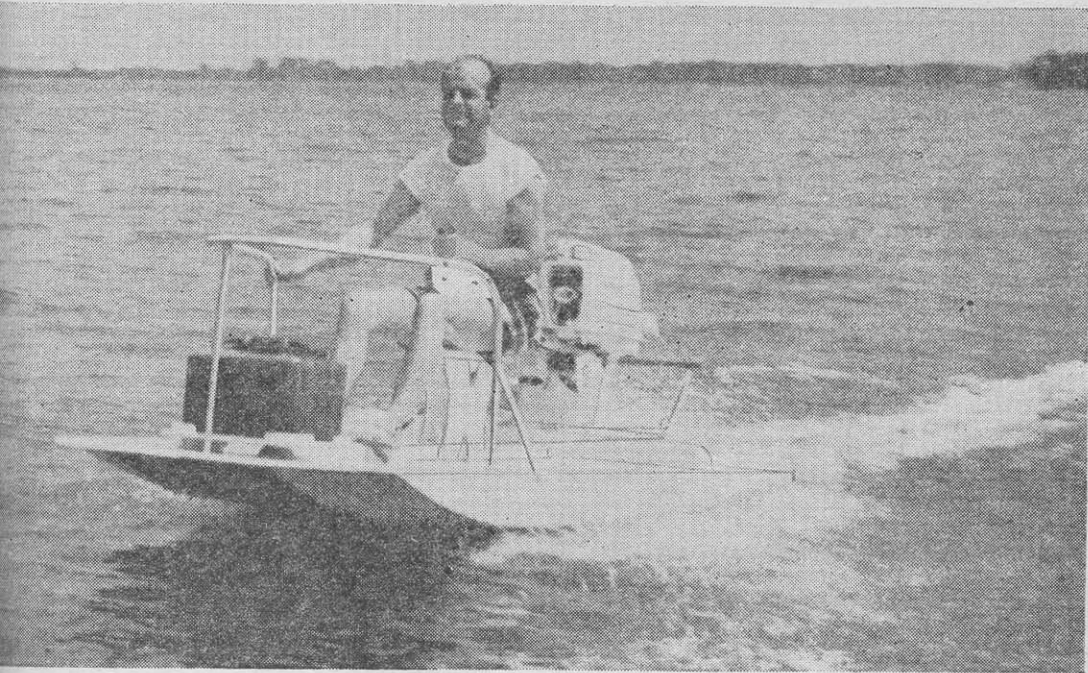

## SPECIFICATIONS

LENGTH... 8 FEET

BEAM... 4 FEET

SPEED... 10MPH@5HP

36MPH@18HP

**Z**IPPER rides like a pair of water skis except that you can maneuver like a star in a water thrill show by gently nudging the tiller bar with your feet. Your hands are free to operate the throttle and apply plenty of body-english to your turns. Speeds up to 36 *mph* are possible with 18-*hp* motors, but even a little 5-*hp* kicker will perform to please the most jaundiced boating fan.

To get this performance, Zipper was designed with twin hulls forward, leading into a conventional planing surface aft. Construction is of exterior-grade AC fir plywood and fir lumber. All materials are available from your local lumberyard or hardware store and should be on hand when you begin construction. No great amount of workshop space is necessary, because the framing will be assembled directly on the 1/2-in. plywood deck.

Begin, as I did, by laying out the deck (Fig. 5A) directly on the 1/2-in. plywood. First draw in the centerline and the tapered sides, then the radius for each bow, finally the cutaway for the motor well. When finished, cut the deck out and set it up on saw horses, so the framing can be assembled on it.

**One Pattern.** Next make a cardboard pattern for the side planks (Fig. 5B). This pattern will be used to lay out the curves of the keelsons (Fig. 4A) and the center strut (Fig. 4G) as well. Use a wooden batten to draw the curved section of the pattern, then cut it out and trace the outline on the stock for each part. Complete the layouts, using the appropriate lengths and tapers.

After bandsawing these parts to shape, locate and cut lightening holes in the keelsons and center strut with a 2-in. hole saw. These holes will not only lighten Zipper and improve performance, they also are used as clearance holes for the bolts that secure the framing parts to the deck.

Use the cardboard pattern again to lay out the curved chines (Fig. 4C) and the keelson doublers (Fig. 4B). Saw these parts to shape and attach them to the curved edges of the keelsons and side planks with glue and #8 x 1 1/4-in. *fh* screws spaced 3 in. apart.

Before attaching the keelson, strut, or side planks to the deck, cut #2 frame (Fig. 3B) to length, mark a centerline across its width,

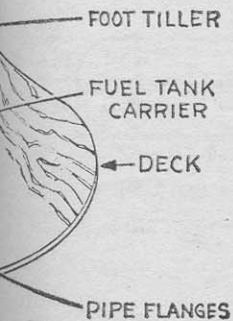

and cut the 2-in. holes. Notch the fore side of the frame on the centerline to take the aft end of the center strut.

Next cut and bevel the 2x4 stock for the transoms (Fig. 4K) and the motor well sides (Fig. 4L), rabbeting the well sides to take the inboard ends of the 16-in. transoms. Now check the fit of all framing parts by temporarily assembling them on the plywood. When each piece fits, trace its outline on the deck and mark the location of the #1 frame as in Fig. 4A. Cut the 1x6 stock (Fig. 3A) to fit between the center strut and the side planks.

Locate the bolt holes (Fig. 4F) in the outlines for the center strut and #2 frame, being sure these coincide with the centers of the 2-in. holes. After drilling 1/4-in. holes in the deck at these locations, use the holes to locate matching holes in the frame, strut, deck stringer, and the crossmember (Fig. 4). Also drill four 1/8-in. holes in each outline to locate nails to hold the parts during assembly.

Next coat the contacting surfaces of the side planks, well sides, transoms, and #2 frame with *Staytite* butyl caulking compound, and clamp these in place while you drive 1 1/2-in. ringed nails through the locating holes. With

these parts in place, coat the contacting surfaces of the keelsons, center strut, and #1 frame halves with glue and attach them in the same way. Fasten the lock piece (Fig. 3A) in the notches of #1 frame and the center strut. When the glue has dried, secure the assembly with 1/4-in. carriage bolts, using flat washers to avoid crushing the wood fibers.

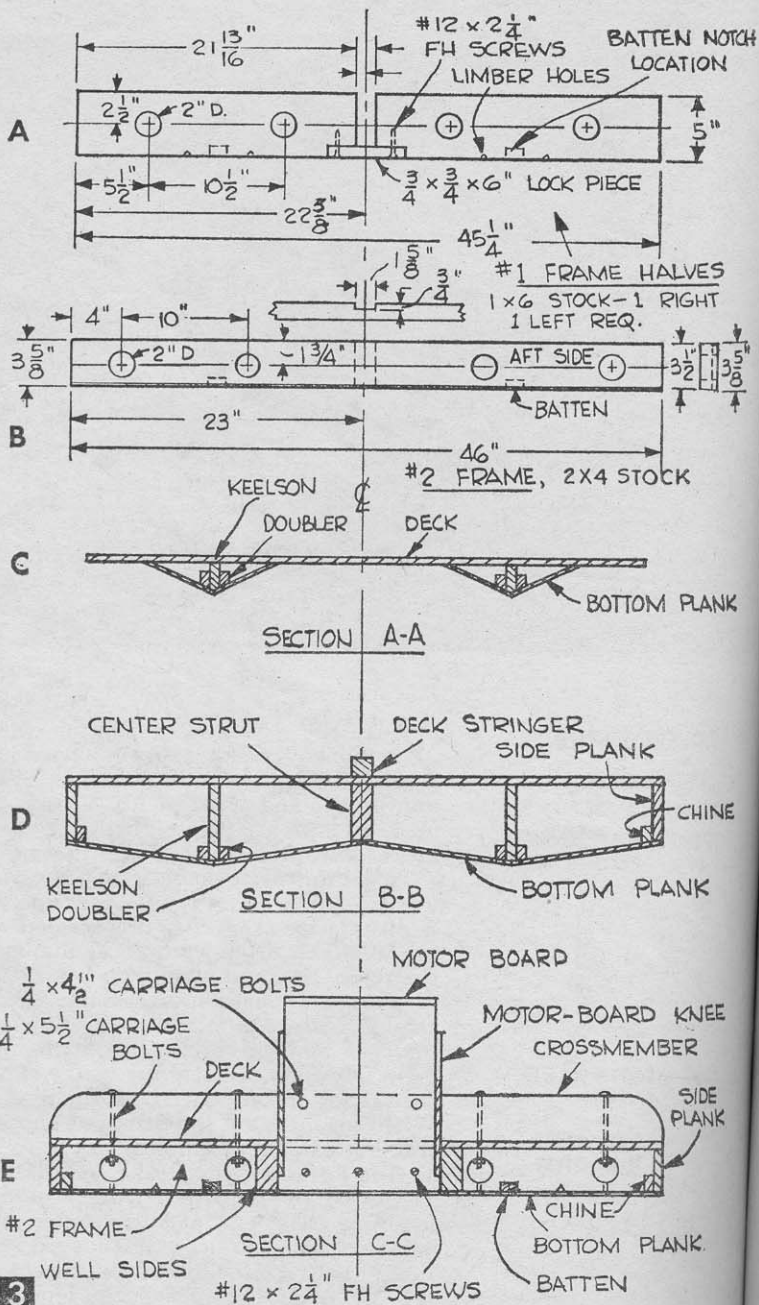

Next clamp the fore ends of the battens (Fig. 4D) to the keelsons and notch them flush into frames #1 and #2. Then permanently attach these to the frames with glue and one #8 x 1 3/4-in. fh screw and to the keelsons with glue and four screws.

Now cut and fit the straight portions of the chines (Fig. 4D) and attach these with

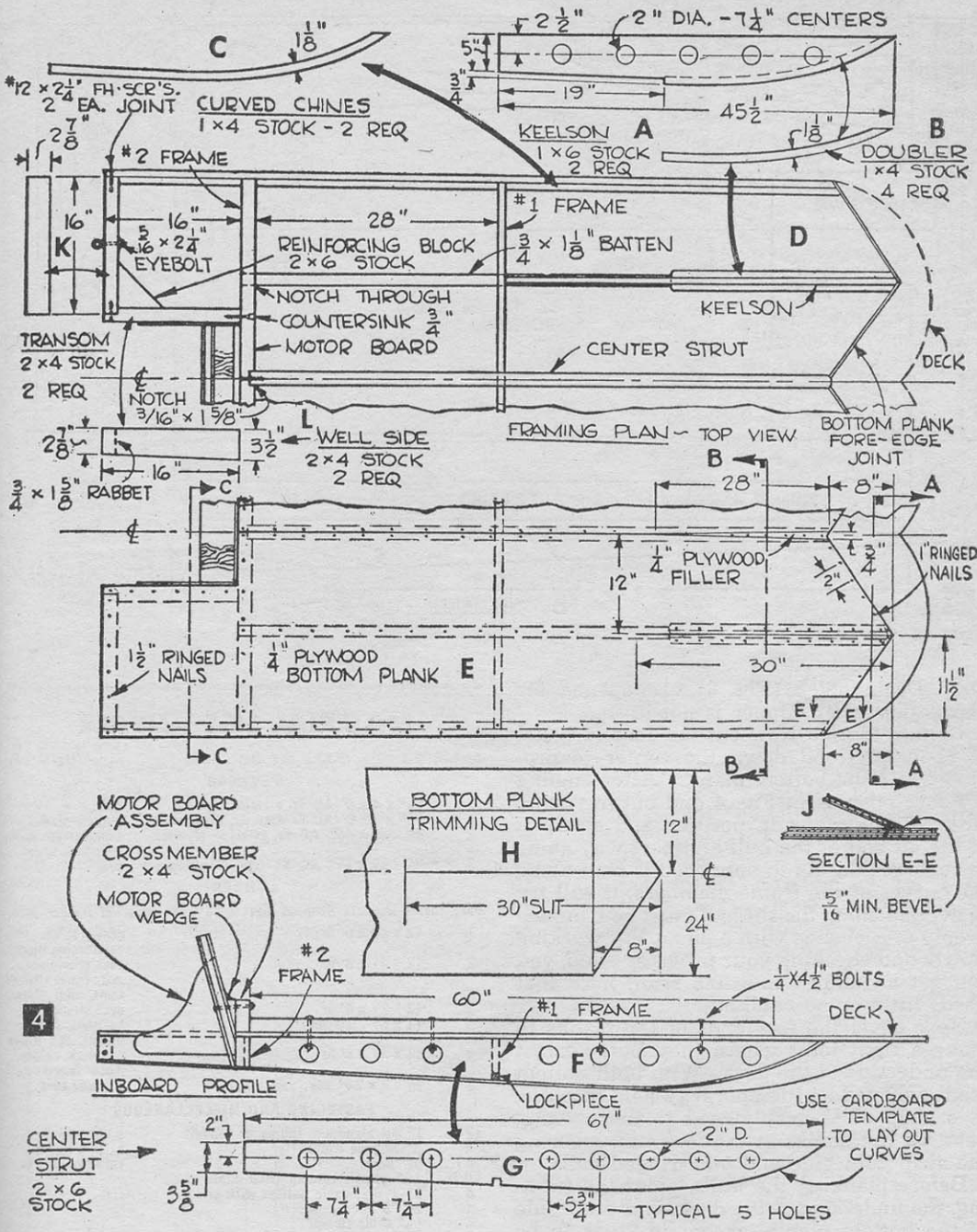

glue and #8 x 1 1/4-in. fh screws and attach reinforcing blocks at the inboard end of each transom, using glue and #12 x 2 1/4-in. fh screws.

Also install a 5/16 x 2 1/2-in. eyebolt in the center of each transom to use when towing water skiers or as tie-downs when Zipper is riding on top of the family bus.

Next, using a 1/4 x 1 x 24-in. wooden batten, fair the framing so the planking can be attached smoothly. Lay the batten over the framing in the area to be covered to locate the high spots. Trim these away with a plane or a Stanley *Surform* rasp. At this same time, cut the triangular limber holes (Fig. 3) to avoid trapping water in any part of the

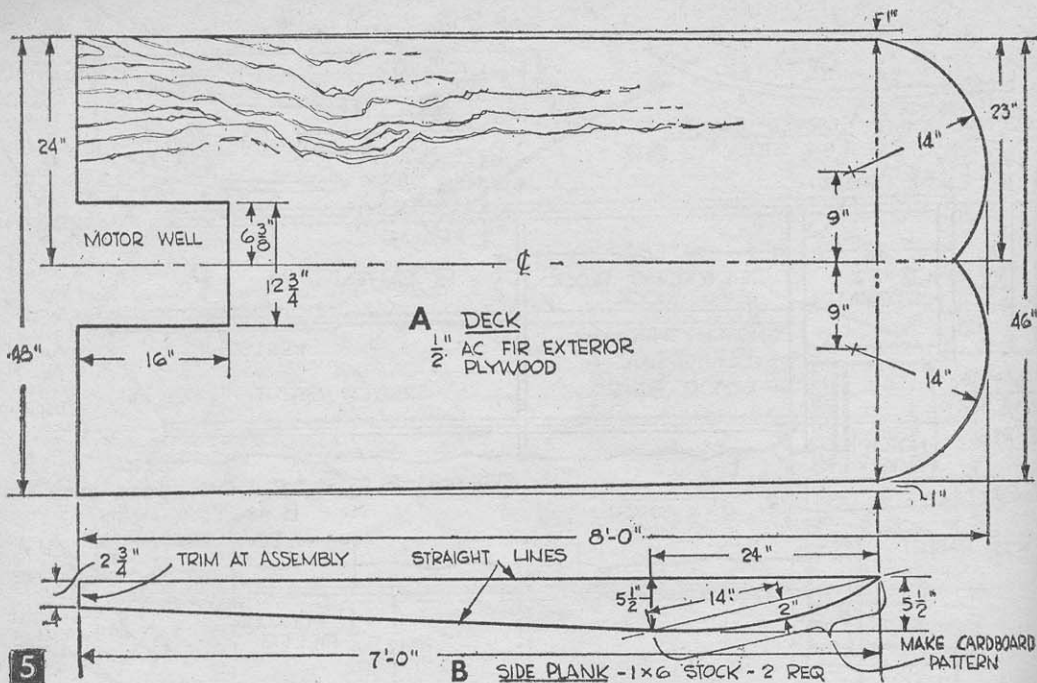

hull. Drain holes (Fig. 8) are opened for ventilation when Zipper is not in use.

**Bottom Plank.** Now cut the 4 x 8-ft. panel of 1/4-in. plywood down the center to provide two 24-in. bottom planks. After angling the fore ends as in Fig. 4 and cutting 30-in. slits, set one plank in position and clamp it at the aft end of the hull and part way along the side plank. As the plywood is bent along the curves of the frame members, it will try to overlap along the slit and must be trimmed evenly at each side with a plane. By working slowly and checking your progress often, you can get an almost invisible seam here that needs little or no caulking.

Next bevel the fore ends of the planks to make a tight joint where they butt against the underside of the deck. With both bottom planks shaped and temporarily held in place, fit a strip of 1/4-in. plywood to the opening between the planks at the fore end, securing the strip with glue and 1-in. ringed nails.

Before planking the hulls, paint the framing, the underside of the deck, and the inside of the bottom plank—except to areas to be glued—with a pentachlorophenol wood preservative such as Sear's *Penta*.

Then apply glue to the center strut and #1 frame and butyl caulking compound to #2 frame, side planks, well sides, and transoms so you can permanently attach the bottom planks with 1-in. ringed nails spaced 2 in. apart. Use a thick mixture of sawdust and glue at the joint between the bottom planks and the deck. When the glue has dried, cut

## MATERIAL LIST—ZIPPER

| Amt. Req.                                                          | Size and Description                            | Use                                             |
|--------------------------------------------------------------------|-------------------------------------------------|-------------------------------------------------|
| <b>PLYWOOD</b>                                                     |                                                 |                                                 |
| 1                                                                  | 1/2" x 4 x 8' AC fir exterior plywood           | deck                                            |
| 1                                                                  | 1/4" x 4 x 8' AC fir exterior plywood           | bottom planks                                   |
| 1                                                                  | 3/8 x 36 x 48" AC fir exterior plywood          | tank carrier, seat supports, knees              |
| 1                                                                  | 3/4 x 12 x 15" AC fir exterior plywood          | seat                                            |
| <b>LUMBER</b>                                                      |                                                 |                                                 |
| Parentheses indicate nominal sizes used when ordering lumber only. |                                                 |                                                 |
| 1                                                                  | (2 x 6) x 6' fir                                | center strut, reinforcing blocks                |
| 2                                                                  | (2 x 4) x 8' fir                                | deck crosspiece, #2 frame, transoms, well sides |
| 1                                                                  | (2 x 2) x 6' fir                                | deck stringer                                   |
| 3                                                                  | (1 x 6) x 10' fir                               | keelsons, side planks, #1 frame                 |
| 4                                                                  | (1 x 4) x 8' fir                                | doublers, chines, motor board core              |
| 2                                                                  | 3/4 x 24" oak, ash, maple                       | steering bars                                   |
| <b>FASTENING AND MISCELLANEOUS</b>                                 |                                                 |                                                 |
| 12 ft.                                                             | 1" od aluminum tubing or conduit                | hand railings                                   |
| 4                                                                  | 1" id pipe flanges                              | railing mounts,                                 |
| 2 ft.                                                              | 3/4" pipe                                       | railing supports                                |
| 20 ft.                                                             | 1/4" plastic-covered tiller cable               |                                                 |
| 4                                                                  | 1 1/2" dia. cable pulleys with strap            |                                                 |
| 4                                                                  | 2" "S" hooks                                    |                                                 |
| 4                                                                  | 1/4" cable clamps                               |                                                 |
| 24                                                                 | #12 x 2 1/2" fh galvanized screws               |                                                 |
| 12                                                                 | #8 x 1 3/4" fh galvanized screws                |                                                 |
| 12                                                                 | #8 x 1 1/4" fh galvanized screws                |                                                 |
| 12                                                                 | #8 x 1" rh galvanized screws                    |                                                 |
| 2                                                                  | 5/16 x 2" eyebolts, flat washers, nuts          |                                                 |
| 2                                                                  | 1/4 x 2" eyebolts, flat washers, nuts           |                                                 |
| 2                                                                  | 1/4 x 3" screw eyes                             |                                                 |
| 1                                                                  | 5/16 x 4" lag screws                            |                                                 |
| 4                                                                  | 1/4 x 5 1/2" carriage bolts, flat washers, nuts |                                                 |
| 6                                                                  | 1/4 x 4 1/2" carriage bolts, flat washers, nuts |                                                 |
| 1 lb.                                                              | 1" Stronghold or Anchorfast nails               |                                                 |
| 1 lb.                                                              | 1 1/2" Stronghold or Anchorfast nails           |                                                 |
| 1 lb.                                                              | Weldwood waterproof glue powder                 |                                                 |
| 1 qt.                                                              | Staylite butyl caulking                         |                                                 |

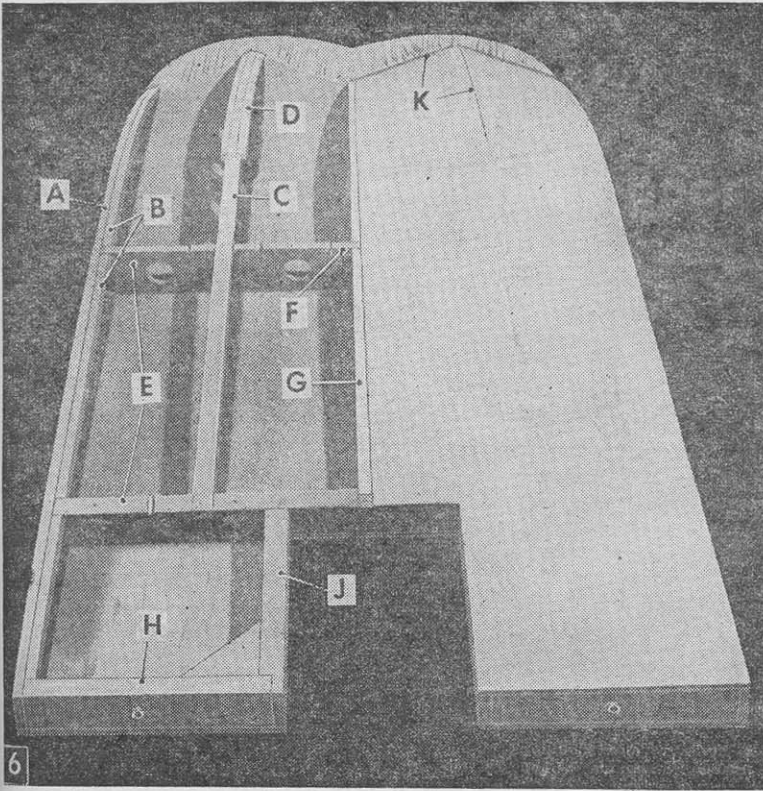

A) side plank; B) chines; C) keelson; D) doubler; E) frames; F) lock piece; G) center strut; H) transom; J) well side; K) bottom plank joints.

away the plywood at the motor well and then disk-sand the planking joints smooth.

**Painting.** When finished, apply one coat of wood preservative and three coats of a brightly-colored porch-and-deck enamel to the underside of the hull. Then turn the hull over and—after driving 1½-in. ringed nails

at 2-in. intervals in the side planks, well sides, and transoms—paint the top and sides in the same way.

Next make the laminated motor board (Fig. 7) from two pieces of ¾-in. plywood and a ¾-in. glued-up lumber core. Glue the plywood to the core and clamp until dry, then bevel the lower edge 15° on a table saw (Fig. 7A). Save the cut-away portion to be used as a wedge between the installed motor board and the deck crossmember (Fig. 4F). Coat the contacting surfaces of the motor board and hull with butyl sealer and fasten the board to the frame with three #10 x 2-in. fh screws and to the crossmember with two ¼ x 5-in. carriage bolts, nuts, and flat washers. To further support the motor board, install a ¾-in. plywood knee (Fig. 7C) at each side,

attaching these to the well sides and to the board with glue and 1½-in. ringed nails spaced 1½-in. apart.

Use ¾- or ¼-in. plywood for the fuel tank carrier base (Fig. 8D) and attach four cleats cut from ¾-in. plywood to this. The carrier on the original Zipper was designed to hold

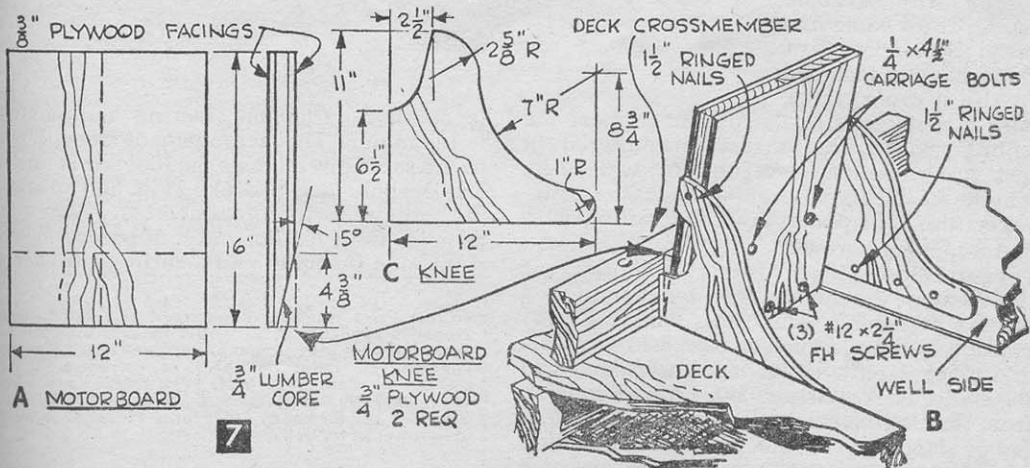

the portable tank used with a 1961 Mercury outboard motor, but slight changes will adapt it to most other tanks.

The  $\frac{3}{4}$ -in. plywood seat (Fig. 8C) is cut next and a 12-in. length of 2x4 is fastened to the underside of it with glue and three #8x1 $\frac{3}{4}$ -in. fh screws. The seat is then set up on two  $\frac{1}{4}$ -in. plywood struts (Fig. 1) attached to the 2x4 with glue and 1 $\frac{1}{2}$ -in. ringed nails. The struts are then fastened to the deck stringer with  $\frac{1}{4}$ x3-in. carriage bolts passing through the struts, stringer, and a  $\frac{3}{4}$ -in.-thick lumber shim at each side of the stringer.

Make the deck railing from a single 10-ft. length of 1-in. aluminum tubing or conduit bent as in Fig. 8 with a tube bender or electrician's hickey. This tool can be rented from most hardware stores when you purchase the tubing, or you can buy one by mail order.

Secure the tubing ends to the deck with flanges and #9x1-in. rh screws. Support the forward end of the railing with a 22-in. length of the same material set in a flange at the deck and fastened to the main railing with a metal strap. To further support the railing against side thrust encountered in fast turns, flatten each end of two 12-in. lengths of  $\frac{3}{4}$ -in. pipe and attach these between the side planks and the railing with metal-tapping screws.

**Foot Tiller.** Zipper uses a foot tiller bar that leaves the hands free for handling a camera or fishing. Make this bar (Fig. 8A) out of a hardwood such as oak, ash, or maple and pivot it on a  $\frac{1}{16}$ -in. lag screw driven in the center deck stringer. Lead the tiller cable from the outboard ends of this bar to a pulley mounted at the deck crossmember. At this point, the cables cross over and run

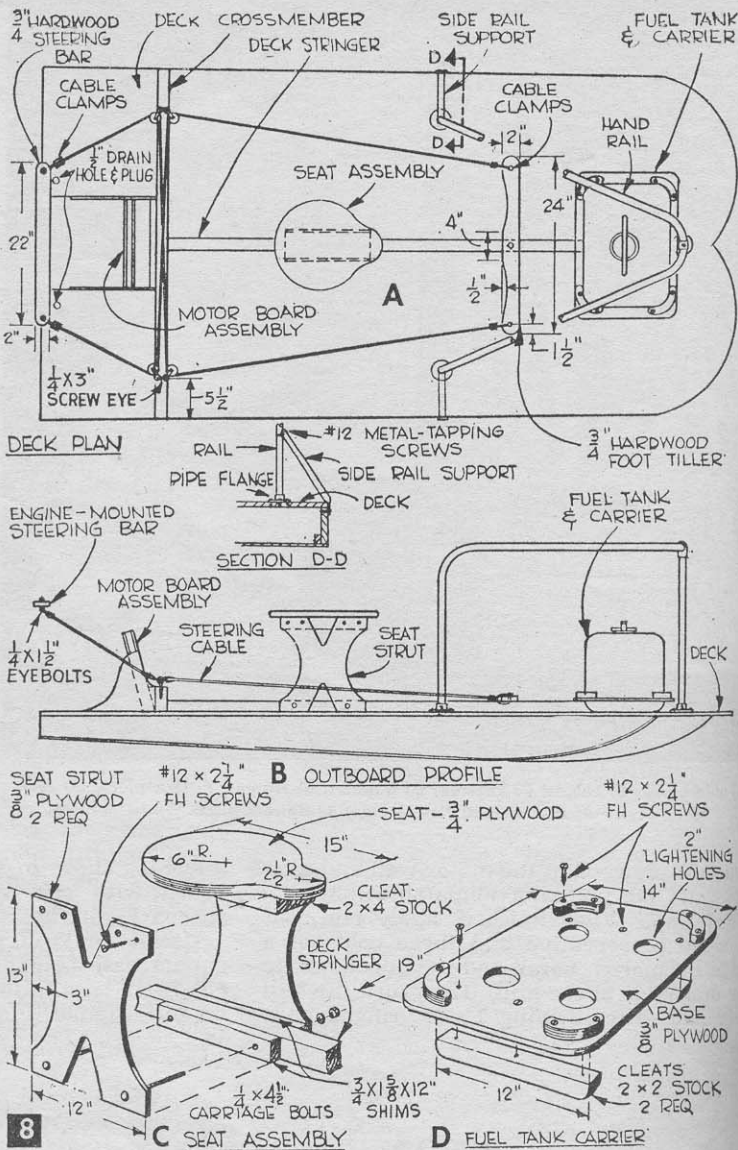

to another hardwood steering bar mounted to the motor. This arrangement steers Zipper in the same direction as the foot bar is turned. Use eyebolts and S-hooks (Fig. 8B) to attach the cable to the crossmember. Fasten the cable to the eyebolts and foot bar by looping it through the holes and securing with clamps.

• Craft Print No. 333 in enlarged size for building Zipper is available at \$3. Order by print number. To avoid possible loss of coin or currency in the mail, we suggest you remit by check or money order (no C.O.D.'s or stamps) to Craft Print Dept., SCIENCE AND MECHANICS, 229 Park Ave. South, New York, N.Y. 10003. See page 112 for handy order form. Please allow three to four weeks for delivery.

